



Unique anabolic action of stem cell gene therapy overexpressing PDGFB-DSS6 fusion protein in OVX osteoporosis mouse model



Wanqiu Chen^{a,1}, Samiksha Wasnik^{a,*}, Yawen Fu^a, Leslie Aranda^a, Charles H. Rundle^{a,b}, Kin-Hing William Lau^{a,b}, David J. Baylink^a, Xiaobing Zhang^a

^a Department of Medicine, Division of Regenerative Medicine, Loma Linda University, Loma Linda, California, USA

^b Musculoskeletal Disease Center, Jerry L. Pettis Memorial Veterans Affairs Medical Center, Loma Linda, CA, USA

ARTICLE INFO

Keywords:

Osteoporosis
OVX
PDGFB
DSS6
Fusion protein
Stem cell therapy

ABSTRACT

In the present study we sought to improve the efficacy and safety of our Sca1⁺ PDGFB stem cell gene therapy for osteoporosis in ovariectomized (OVX) mouse model. This therapy is administered by marrow transplantation. We established the promise of this approach by previously showing that this therapy in normal mice increase bone density, increased endosteal cortical and trabecular bone formation, caused de novo trabecular bone formation, increased cortical thickness and improve bone strength. In the current study we produced a fusion gene, PDGFB-DSS6. We reasoned that the DSS6, calcium binding protein would trap the PDGFB at the bone surface and thereby limit the amount of PDGFB required to produce an optimal bone formation response, i.e. efficacy with a lower engraftment. The result shows that indeed with a very low level of engraftment we achieved a large increase in bone formation in the OVX model of bone loss. Serum analysis for biochemical marker of new bone formation showed an approximate 75% increase in alkaline phosphatase levels in Sca1⁺ PDGFB-DSS6 group as compared to other groups. Quantitative analysis of bone by microCT showed a massive increase in trabecular bone density and trabecular connectivity of the femur in the metaphysis in Sca1⁺ PDGFB-DSS6 group. The increased cortical porosity produced by OVX was replaced by the Sca1⁺ PDGFB-DSS6 therapy but not by the positive control Sca1⁺ PDGFB. Additionally, an increase in the femur bone strength was also observed specifically in Sca1⁺ PDGFB-DSS6 as compared to other treatment groups, emphasizing the functional significance of the observed anabolic action is on bone formation. In future work we will focus on nontoxic preconditioning of our marrow transplantation procedure and also on transcriptional control of therapeutic gene expression to avoid excess bone formation.

1. Introduction

In the US alone, there are 10 million non-traumatic fragility fractures annually (*Osteoporosis: Fragility Fracture Risk: Osteoporosis: Assessing the Risk of Fragility Fracture*, 2012). The most common osteoporosis-associated fracture is a vertebral compression fracture, which is associated with substantial morbidity (Kanis, 1994). Antiresorptive therapy has been shown to decrease vertebral fractures by 50%. Hip fracture is much less common, but has 14–58% mortality within one year of fracture (Schnell et al., 2010; Panula et al., 2011). Antiresorptive therapy only decreases non-vertebral fractures by 20–30% (Kawai et al., 2011). Interestingly, anabolic therapies have been shown to reduce non-vertebral and vertebral fractures by 35–60% (Minisola

et al., 2017; Rubin and Bilezikian, 2002; Neer et al., 2001). In addition, current anabolic therapies are expensive, require strict compliance, and lose their effectiveness in 1–2 years (Kawai et al., 2011). Therefore, a stronger anabolic agent with a prolonged activity is considered to be a major unmet therapeutic need in the treatment of osteoporosis.

One of the most important recent and novel findings on the pathogenesis of osteoporosis is the identification of senescent bone cells, mostly osteocytes but also osteoprogenitor cells (Farr et al., 2016). Senescent cells are nonproliferating cells that secrete products detrimental to surrounding cells in tissue microenvironment. One might expect that the accumulation of senescent cells would inhibit the action of anabolic agents. However, this does not seem to be the case because of the universal success of parathyroid hormone (PTH)-like medications

* Corresponding author at: Department of Medicine, Division of Regenerative Medicine, Loma Linda University, Loma Linda, CA 92354, USA.

E-mail addresses: WChen@llu.edu (W. Chen), Swasnik@llu.edu (S. Wasnik), YFu1@llu.edu (Y. Fu), Charles.Rundle@va.gov (C.H. Rundle), William.Lau@va.gov (K.-H.W. Lau), DBaylink@llu.edu (D.J. Baylink), XZhang@llu.edu (X. Zhang).

¹ These authors equally contribute to this work

<https://doi.org/10.1016/j.bonr.2019.100236>

Received 8 May 2019; Received in revised form 6 December 2019; Accepted 9 December 2019

Available online 11 December 2019

2352-1872/ © 2019 The Authors. Published by Elsevier Inc. This is an open access article under the CC BY-NC-ND license (<http://creativecommons.org/licenses/by-nc-nd/4.0/>).

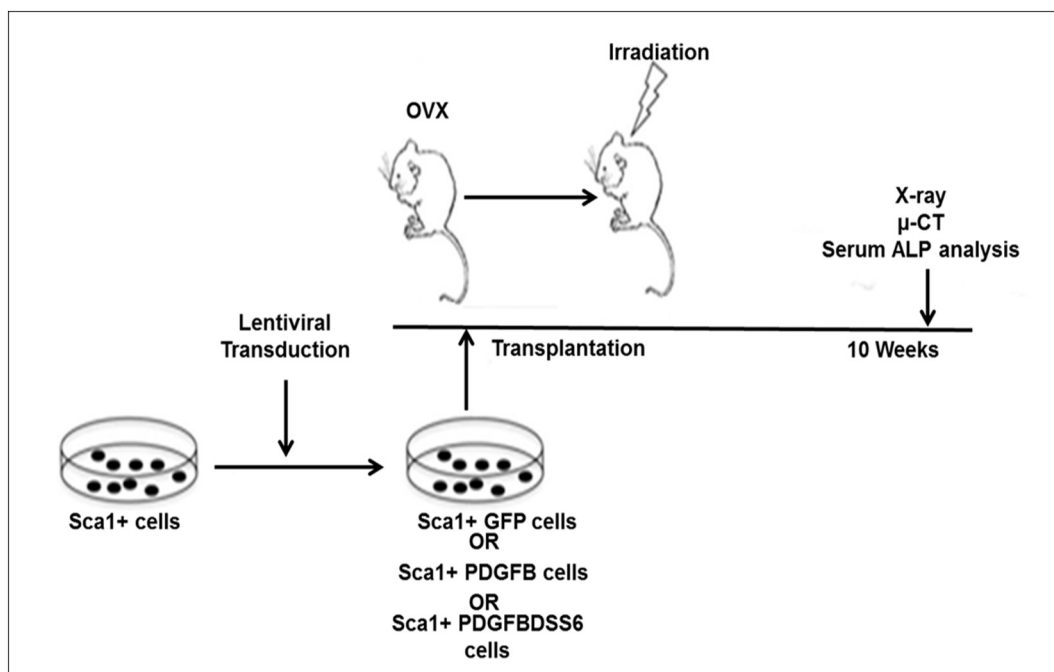

Fig. 1. Schematics of the experimental design. Two weeks after OVX or sham surgery animals undergo irradiation and transplantation with Sca1⁺ cells that were transduced with lenti-GFP or Sca1⁺-PDGFB or Sca1⁺-PDGFB-DSS6, and bone tissues were analyzed 10 weeks later.

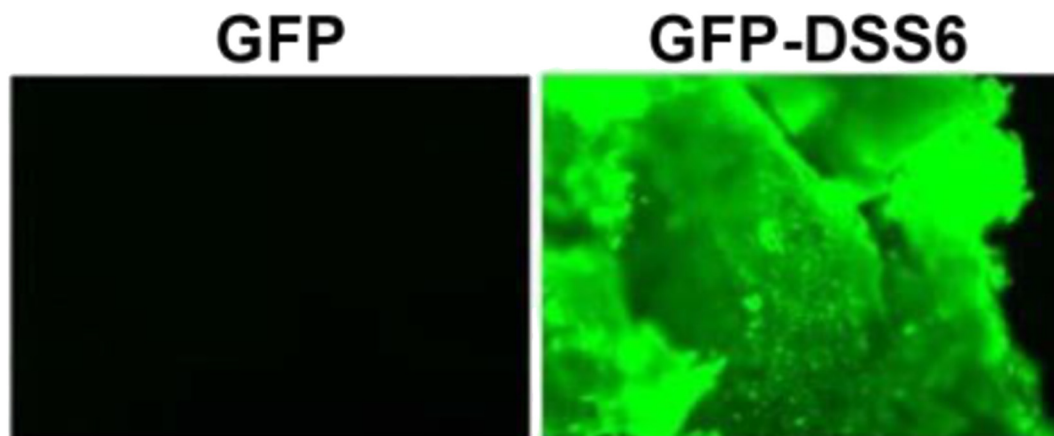

Fig. 2. DSS6 endows a bone surface binding ability to GFP. As mentioned in the method section, the bone slices were incubated for 1 h with 50 ng/ml of green fluorescent protein (GFP) or GFP-DSS6. The bone slices were then rinsed extensively with PBS. Representative fluorescence images of the GFP-DSS6-bone slices conjugation are shown here.

(even in the elderly) to stimulate bone formation and reduce fracture risk (Ascenzi et al., 2012; Papapoulos, 2015). Moreover, sodium fluoride, which is a bone cell mitogen, has been shown to produce a marked and prolonged stimulation of bone formation in elderly osteoporotic subjects (Rubin et al., 2001; Kleerekoper and Balena, 1991). Despite its bone anabolic action, sodium fluoride impairs bone quality and therefore is not considered an effective anabolic agent (Kleerekoper et al., 1991; Gutteridge et al., 2002). These observations emphasize the responsiveness of the aged osteoporotic skeleton to regeneration.

With respect to the development of stronger anabolic agents, we have recently developed an anabolic agent, platelet-derived growth factor-B (PDGFB) that cause a massive, prolonged increase in new endosteal and trabecular bone formation in normal mice, which was attended by a marked increase in bone strength (Chen et al., 2015). Regarding safety, PDGFB has been approved by the FDA for promotion of wound healing (Fang and Galiano, 2008). Also in our previous study we found no safety issues regarding PDGF administration (Chen et al.,

2015). The main concern about our approach is that toxic effect of preconditioning needed for marrow transplantation. Marrow transplantation was utilized in order to target the PDGFB to sites of bone loss in humans (Chen et al., 2015); namely, the cortical endosteum, the cortical canals, and trabecular bone (Seeman, 2013). The targeting mechanism that we used was bone marrow transplantation, in which we engineered hematopoietic stem cells (Sca1⁺ cells) to overexpress PDGFB. Total body radiation increases in the bone niche, SDF 1, which is a chemokine for the CXCR4 receptor and expressed by Sca-1 cells. Consequently, the Sca 1 cells localize to the hematopoietic stem cell niche which is a site where bone is lost (Chanda et al., 2010). These Sca-1⁺ cells do not respond by proliferation to PDGFB in vitro, as mentioned earlier paper (Chen et al., 2015)

Total body irradiation or chemotherapy as preconditioning maneuvers is not acceptable for a nonlethal disease, such as osteoporosis. Therefore, we sought to further target PDGFB to the bone surface in an attempt to reduce the Sca1⁺-PDGFB engraftment required for bone

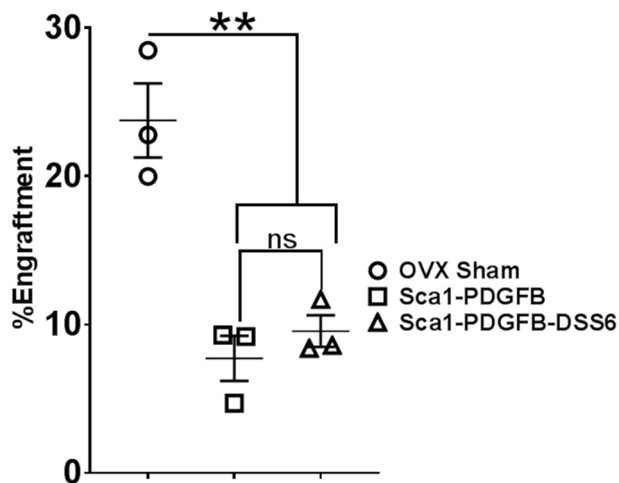

Fig. 3. Bone marrow transplantation and % engraftment. Two weeks after the OVX surgery, the C57/BL6 mice were divided into 2 groups, and transplanted with Sca1⁺ cells that were transduced with, 1) Lenti GFP-PDGFB (wild-type), and 2) Lenti GFP-PDGFB-DSS6. OVX sham surgery animals were served as control, and transplanted with Sca1⁺ cells that were transduced with Lenti GFP. To ensure engraftment of hematopoietic stem/progenitor cells, mice were myeloablated by irradiation at 8 Gy before transplantation. Ten weeks after transplantation, the engraftment level was evaluated by analyzing the bone marrow cells for % GFP⁺ cells by FACS. Data are means ± SEM. ***P* < .01, ns = not significant.

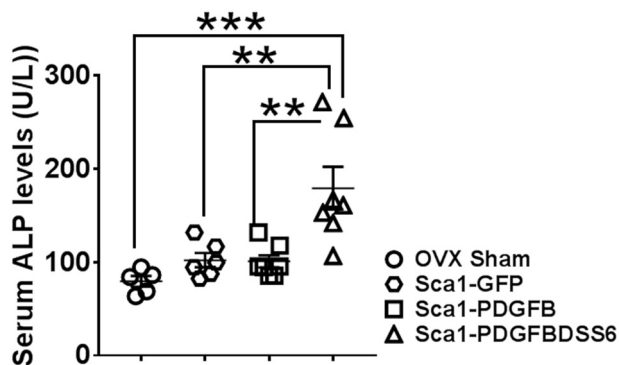

Fig. 4. High serum ALP levels were observed in the Sca1⁺PDGFB-DSS6 treated animals, but not in the Sca1⁺PDGFB treated animals. The measurement was conducted 10 weeks after transplantation. Data are means ± SEM. ***P* < .01, ****P* < .001.

formation. This would be expected to decrease the dose of the preconditioning agent. We reasoned that a calcium-binding peptide attached to the PDGFB might concentrate the PDGFB at the bone surface. In this regard, DSS6 peptide (six repetitive sequences of aspartate, serine, and serine), is a calcium-binding peptide and has been shown to target the bone surface (Yarbrough et al., 2010; Zhang et al., 2012). Our proposed strategy takes advantage of the high affinity of a unique DSS6 peptide for calcium and employs this peptide as a novel targeting vehicle to deliver and retain an osteogenic growth factor, PDGFB (in a fusion protein form with DSS6), at the site of bone loss. The goal of the present study was to perform a preliminary experiment to test our hypothesis that marrow transplantation with Sca1⁺ PDGFB-DSS6 would exhibit greater bone formation than with Sca1⁺ PDGFB. We chose the head of the femur for our sampling site. We sought to evaluate efficacy before proceeding with elaborate studies of the safety.

2. Material and methods

2.1. Animal study

Female C57BL/6J mice of 6 to 8 weeks of age were purchased from the Jackson laboratory. All experimental protocols were approved by the Institutional Animal Care and Use Committee at Loma Linda University and the Animal Care and Use Review Office of the United States Department of the Army. In conducting research using animals, the investigators adhered to the Animal Welfare Act Regulations and other Federal statutes relating to animals and experiments involving animals and the principles set forth in the current version of the Guide for Care and Use of Laboratory Animals, National Research Council.

2.2. Ovariectomy surgery

Ovariectomy (OVX) surgery was conducted on 2-month old C57BL/6 J female mice. Mice were anesthetized by an intraperitoneal injection of 105 mg/kg ketamine and 21 mg/kg xylazine (in a total of ~0.1 ml volume). Body temperature was maintained by a 37 °C recirculating-water heating pad. The back and sides of the mice were shaved and cleaned with 70% ethanol and Betadine. Under aseptic conditions, the pair of ovaries was removed from the mice by dorsal incision into the region between the dorsal hump and the base of the tail. Removal of the fimbrial end of the fallopian tube was done to ensure completeness of the ovariectomy. The muscle incision was closed with 6–0 silk sutures, and skin incisions closed with 3–0 silk sutures. Post-operative analgesic (0.060 mg/kg in 0.05 ml buprenorphine, subcutaneously) was administered for each mouse. After surgery, animals were treated for two days, twice a day, with buprenorphine, and monitored closely thereafter. The animals were observed during recovery until alert and mobile. The surgical procedure for control, sham-operated mice was the same, except that the ovaries were not removed (Thompson et al., 1995).

2.3. Bone marrow (BM) Sca1⁺ cell isolation

Bone marrow Sca1⁺ cell isolation was performed as previously described (Chen et al., 2015). Briefly, bone marrow cells were harvested from mice femurs and tibias, and Sca1⁺ cells were purified using Sca1⁺ MACS magnetic beads (MiltenyiBiotec, cat no 130-106-641). Before viral transduction, cells were cultured for 48 h. in Iscove's modified Dulbecco's medium (IMDM, Invitrogen) containing 10% FBS (Invitrogen) and 100 ng/mL each of human TPO, mouse SCF, human Flt3L, human IL-3, and human G-CSF (Chen et al., 2015).

2.4. Lentiviral vectors and transduction of Sca1⁺ cells

Human PDGFB ORF was subcloned into a lentiviral vector and fused with DSS6 peptide under the control of the PGK promoter. Lentiviral packaging was performed as previous described (Chen et al., 2015). SIN lentiviral vectors were produced by transient transfection of the vector plasmid in human 293T cells along with helper plasmid (CMVdR8.74) and envelope plasmid (MD.G). Sca1⁺ cells were transduced once at a MOI of 2 for 6 h. in six-well nontissue culture-treated plates precoated with RetroNectin (Takara). From here onwards the lenti Sca1⁺-GFP-PGK-PDGFB construct will be mentioned as Sca1⁺-PDGFB and Sca1⁺-GFP-PGK-PDGFB-DSS6 as Sca1⁺-PDGFB-DSS6 throughout the article.

2.5. Transplantation

Two weeks after ovariectomy surgery, OVX mice were irradiated with a ⁶⁰Co source (Eldorado model, Atomic Energy of Canada) at a single dose of 8 Gy (0.543 Gy/min) in the Department of Radiation Medicine of the Loma Linda University. Twenty-four hours later, 1 × 10⁶ lentiviral transduced Sca1⁺ cells were resuspended in 200 μL

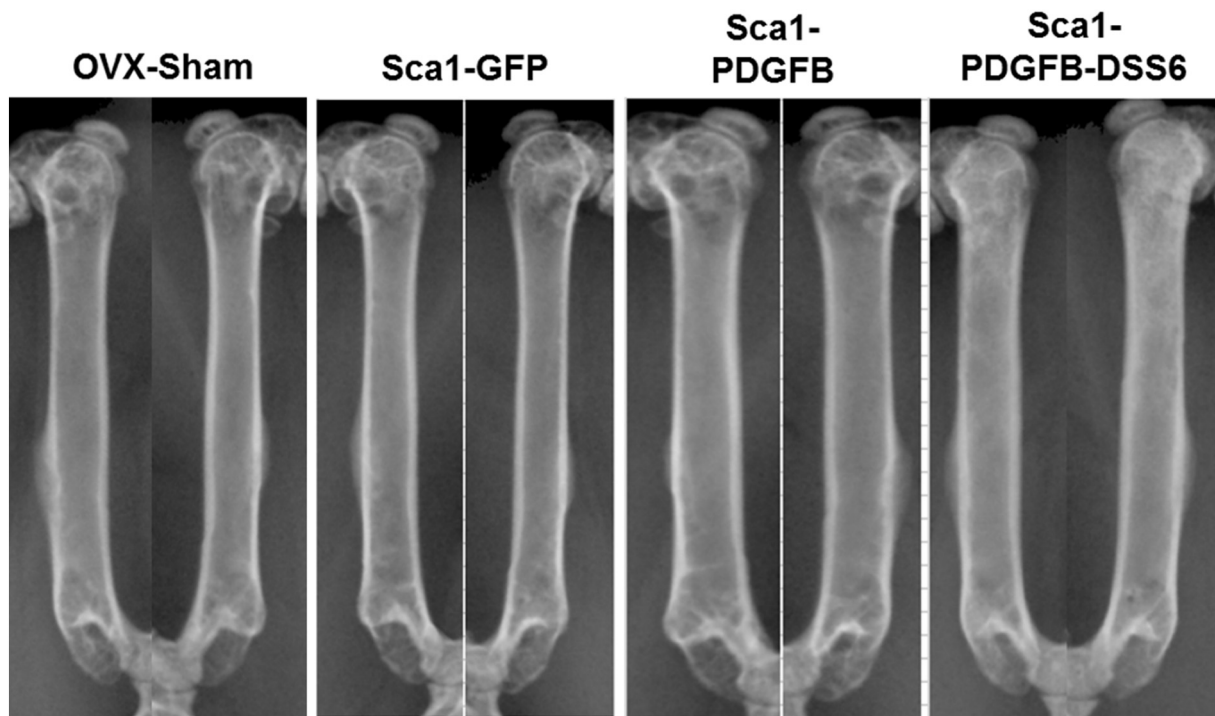

Fig. 5. Representative X-ray pictures of femurs harvested from mice received Sca1⁺ GFP control, Sca1⁺ PDGFB or Sca1⁺ PDGFB-DSS6 cells. In each group, 6–7 mice underwent OVX to induce osteopenia, followed by hematopoietic stem/progenitor cell transplantation 2 weeks later. Animals were analyzed at 10 weeks after transplantation.

IMDM and transplanted into each recipient mouse via tail vein injection under anesthesia. The mice were restrained in the mouse restrainer during tail vein injection, and then properly returned to their cages (Chen et al., 2015).

2.6. μ CT analysis

A μ CT analysis of the femoral bone was performed using a Scanco VivaCT 40 instrument (Scanco Medical). Femurs were scanned at an isotropic voxel size of 10.4 μ m³, and energies of 55 keV and 70 keV were used to scan the distal metaphysis and the midshaft, respectively. For metaphyseal analysis, the region of interest included the intramedullary space inside the endosteal surface at a distance proximal to the condylar growth plate that was normalized for femur length. The midshaft analysis region of interest used two contours to include the cortex and exclude the intramedullary space, and was also normalized for any variations in bone length. Within their respective regions of interest, trabecular bone was segmented at a density of > 220 mg/cm³ and the cortical bone segmented at a density of > 260 mg/cm³. Trabecular and cortical partial bone volume (BV/TV) was determined. Trabecular number, thickness and spacing were also examined, as was the trabecular connectivity density. Cortical porosity was calculated as 1 – BV/TV (midshaft) from the two-contour examination of the femoral midshaft cortex (Chen et al., 2015).

2.7. Bone strength analysis

The mechanical strength of the femurs was evaluated at midshaft by the three-point bending test, using an Instron DynaMight 8841 servo-hydraulic tester (Instron). Bones were stored frozen in saline-soaked gauze, thawed, and rehydrated in saline before testing. The femur was positioned on the tester with the anterior aspect upwards on supports that were 2 mm in diameter and 7 mm apart. The bone was preloaded to 1 N at the midshaft and then loaded to failure using a blade excursion rate of 5.0 mm/s (Chen et al., 2015).

Sca1-PDGFB

Sca1-PDGFB-DSS6

2.8. Serum Alkaline phosphatase measurement

Serum ALP activity was measured by the QuantiChrom ALP kit (BioAssay Systems) (Chen et al., 2015).

2.9. Effect of PDGFB-DSS6 IV injections on trabecular bone formation

At 1 month after ovariectomy, mice were received with PBS or PDGFB-DSS6 (0.5 mg/kg or 5 mg/kg) i.v. thrice per week for 4 weeks. Representative von Kossa staining images from L3 vertebrae showed increased trabecular bone formation following PDGFB-DSS6 treatment.

2.10. GFP-DSS6 binding to bone chips

We choose DSS6, a six repeating sequence of AspSerSer (Fang and Galiano, 2008; Seeman, 2013), as a fusion partner of PDGFB to allow PDGFB to target mineralized bone surface. We first sought to confirm that DSS6 could efficiently bind and localize DSS6 fusion protein at the bone surface in vitro. Bone chips were first incubated with green fluorescent protein (GFP) or GFP-DSS6 (50 ng/ml) for 1 h, and then washed twice with 1 \times PBS. All images were captured with an Olympus BX51 microscope system (Olympus).

2.11. Statistical analysis

All data were presented as mean \pm SEM. OVX Sham and OVX treated groups were compared by Student *t*-test or one way ANOVA. In other parts two-way and one-way ANOVA were used. A *P*-value < .05 were considered statistically significant.

3. Results

3.1. Experimental strategy

The goal of this study was to study the bone anabolic efficacy of our

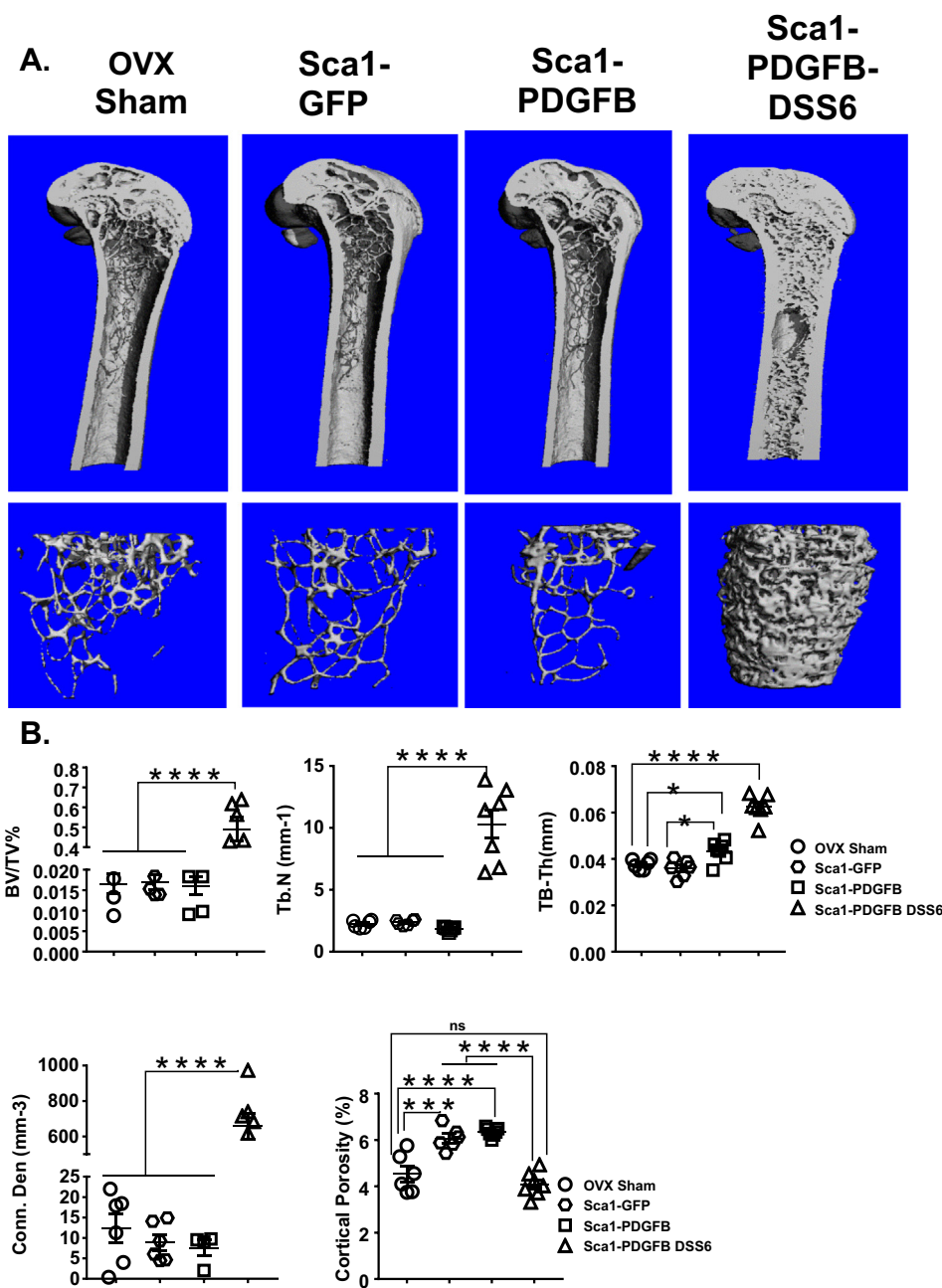

Fig. 6. A) Representative MicroCT 3D pictures of femurs harvested from mice received GFP control, PDGFB or PDGFB-DSS6 overexpressing Sca1⁺ cells. In each group, OVX was performed in 6–7 mice to induce osteopenia, followed by hematopoietic stem/progenitor cell transplantation 2 weeks later. Animals were analyzed at 10 weeks after transplantation. MicroCT three dimensional bone structure analysis of femurs from OVX osteoporosis mouse after treatment with Sca1⁺-PDGFB or Sca1⁺-PDGFB-DSS6. PDGFB-DSS6 is a fusion protein of PDGFB and bone-surface binding peptide DSS6. B) Specimens were analyzed by microCT at 10 weeks after transplantation (n = 4–7). The following parameters of new bone formation from the microCT analysis are shown: trabecular partial bone volume (BV/TV); connectivity density (Conn. Density); trabecular number (Tb.N); trabecular thickness (Tb.Th), and cortical porosity. Data are means ± SEM. ****p < .0001.

stem cell gene therapy in OVX mice. We compared Sca1⁺ cells that were transduced with PDGFB (control) vs. PDGFB-DSS6 (fusion protein with bone specific targeting) to determine whether PDGFB-DSS6 was superior to PDGFB alone in anabolic action. The primary end-point was the amount and distribution of the new bone formed in response to our stem cell gene therapy. Secondary end-points include x-ray imaging of long bones, and serum alkaline phosphatase. Animals were divided into 4 groups: OVX sham, OVX GFP (untreated), OVX Sca1⁺-PDGFB and OVX Sca1⁺-PDGFB-DSS6 (bone targeting). Fig. 1 shows the general experimental design using the lenti transduced Sca1⁺ cells.

GFP-DSS6 binds to bone slices. We first determined the bone-targeting ability of DSS6. Incubation of green fluorescent protein (GFP)-DSS6 fusion protein with bone slices produced an intense green fluorescence as compared with GFP alone, demonstrating that DSS6 fusion protein can target and bind to the bone (Fig. 2).

3.2. Bone marrow transplantation

After total body irradiation each mouse in the stem cell therapy group was injected with 1 million transduced Sca1⁺ cells intravenously. To evaluate the level of engraftment of the Sca1⁺ cells, GFP⁺ cells in peripheral blood was measured at 1 and 2 months after transplantation by FACS analysis. In our Sca1⁺ GFP-OVX control mice, engraftment was about 18%, which is similar to what we have seen in the past (Chen et al., 2015) (Fig. 3). However, in the two OVX groups (PDGFB and PDGFB-DSS6) engraftment was only ~8% (Fig. 3). These results raise the possibility that OVX reduces the engraftment of Sca1⁺ cells.

3.3. Serum ALP at 10 weeks post therapy

At 10 weeks after the stem cell gene therapy, we determined the serum ALP levels, which is a serum biomarker of bone formation.

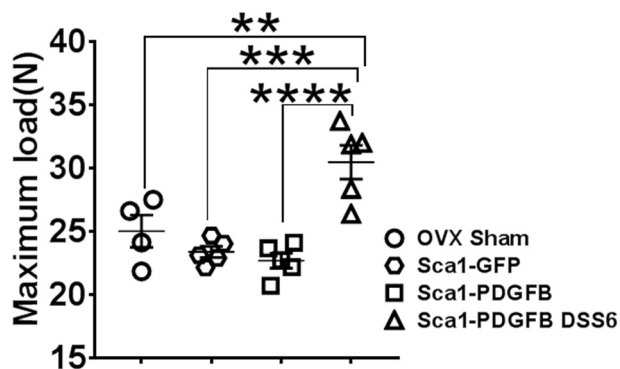

Fig. 7. The Sca1⁺-PDGFB-DSS6 treatment increases bone strength. Representative loading force displacement graph presented. Three-point bending test was used to measure bone strength at the midshaft of the femur. Maximum load-to-failure on Sca1⁺-PDGFB-DSS6 treated femurs was significantly greater than that of the other groups. Data are means ± SEM. ***P* < .01, ****P* < .001, *****P* < .0001.

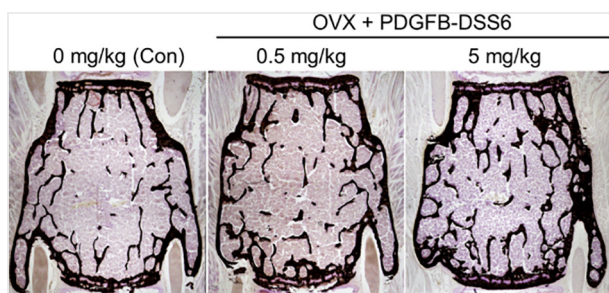

Fig. 8. PDGFB-DSS6 protein promotes bone formation in lumbar vertebrae in OVX mice. At 1 month after ovariectomy, mice were received with PBS or PDGFB-DSS6 (0.5 mg/kg or 5 mg/kg) i.v. thrice per week for 4 weeks. Representative von Kossa staining images from L3 vertebrae showed increased trabecular bone formation following PDGFB-DSS6 treatment.

Compared to the OVX sham group, there was no significant increase in the Sca1⁺ group or the Sca1⁺-PDGFB group. However, the serum ALP was 75% increase in the Sca1⁺-PDGFB-DSS6 group compared to the Sca1⁺-GFP control group (Fig. 4).

3.4. X-ray of the femur long bones

We first determined bone mineral density of femurs at 10 weeks after therapy by X-ray imaging. X-rays showed increased trabecular bone, particularly in the metaphysis and femoral trochanter, and cortical thickening in the Sca1⁺-PDGFB-DSS6 compared to the Sca1⁺-PDGFB and Sca1⁺ groups (Fig. 5).

3.5. μ CT of femur

In the Sca1⁺ PDGFB-DSS6 group there was a massive increase in trabecular bone density of the femur, particularly in the metaphysis compared to the Sca1⁺ GFP control and the Sca1⁺-PDGFB. No difference was seen in any of the μ CT parameters between the Sca1⁺ GFP control and the Sca1⁺ PDGFB (Fig. 6A). No differences in bone density were observed between the sham OVX control and the Sca1⁺ GFP control. However we saw highly significant increases in cortical porosity in the Sca1⁺ GFP group and in the Sca1⁺-PDGFB group compared to the non-OVX group. Accordingly, in this study statistically significant differences in microCT bone parameters in response to OVX were observed only in cortical porosity (Fig. 6B).

Strikingly, we observed a > 20-fold increase in BV/TV in the Sca1⁺ PDGFB-DSS6 compared to the Sca1⁺ PDGFB or the Sca1-GFP controls.

In addition, trabecular number, trabecular thickness and trabecular activity were all much greater in the Sca1⁺ PDGFB-DSS6 than in the Sca1⁺ PDGFB or Sca1⁺ GFP (Fig. 6B).

The connectivity density after Sca1⁺-PDGFB-DSS6 treatment was > 50-fold higher than the Sca1⁺-PDGFB group, suggesting that our therapy has a strong ability to cause de novo bone formation; i.e., trabecular bone formation where there was no bone before. We found increased cortical porosity in Sca1⁺-GFP or Sca1⁺-PDGFB treated mice, likely due to OVX-induced bone loss. However, Sca1⁺-PDGFB-DSS6 treatment completely replenished the lost cortical bone. (Fig. 6B). These data demonstrate that the PDGFB-DSS6 therapy induces de novo bone formation in OVX marrow cavity and corrects cortical bone loss due to OVX.

3.6. Bone strength analysis

We then asked whether the increased trabecular connectivity and decreased cortical porosity would translate into increased strength. Bone strength was measured by the 3-point bending of the right femurs. As expected, the Sca1⁺ PDGFB-DSS6 group showed a significant increase in bone strength compared to the other 3 test groups, including the OVX sham (Fig. 7).

3.7. PDGF-DSS6 protein enhances trabecular bone formation

The striking results of PDGF-DSS6 gene therapy in OVX mice encouraged us to develop the PDGF-DSS6 protein to avoid marrow transplantation. To this purpose, we have conducted preliminary studies. IV injection of PDGFB-DSS6 not only increased bone formation in femurs (not shown), but also in lumbar vertebrae (Fig. 8) in a dose-dependent manner. These results demonstrate that injection of PDGFB-DSS6 protein is efficacious.

4. Discussion

The most salient finding in the present study was huge amount of bone formation produced by our Sca1⁺ PDGFB-DSS6 stem cell gene therapy, which targeted the PDGFB therapy to the bone surface by virtue of DSS6, which is a calcium binding peptide. Here the Sca1 cells are the source for the abundant production of PDGFB-DSS6. This anabolic action of PDGF with the PDGF-DSS6 construct was achieved at a much lower Sca1⁺ cell engraftment compared to our earlier studies (Chen et al., 2015), strongly suggesting a substantial reduction in the ratio of PDGFB produced per unit of the amount of bone formed. The future significance of this lower required anabolic dose is that it should reduce the preconditioning dose required for an optimal anabolic action. Moreover, the overall lower synthesis of PDGFB should reduce off target effects with HSC PDGFB-DSS6 stem cell gene therapy.

In the PDGFB-DSS6 group, there was a large increase in trabecular bone formation. This was associated with an enormous increase in trabecular connectivity. Also there was new trabecular bone formation in sites where trabecular bone had not been present in the past, de novo bone formation. Another advantage of this therapy is to decrease in cortical porosity, which is known to be important for the preservation of bone strength (Augat and Schorlemmer, 2006). Parathyroid hormone like therapeutic agents are also known to produce increased trabecular bone formation (Calvi et al., 2001); whereas, Romosozumab apparently can form new bone, in cortical as well as trabecular regions (McClung et al., 2018; McClung et al., 2014; Graeff et al., 2015) however, the robust anabolic effect of treatment is limited to the first few months of therapy (McClung, 2018). In our previous work we found that PDGFB stem cell therapy increases bone formation in vivo in red and in fatty marrow (Chen et al., 2015). In our earlier study we found evidence for differentiation capacity from the treatment of Sca1⁺ cells over-expressing PDGFB. We found an increase in BMP 2 expression, which presented a conundrum because PDGFB alone does not cause bone cell

differentiation *in vitro*. We concluded that PDGFB had some type of secondary action in the marrow space which led to an increase in BMP 2. It requires the marrow space for PDGFB to have this action because when PDGFB was given to rats it did not increase periosteal bone formation (Mitlak et al., 1996). In our previous study of the treatment of normal mice with PDGFB via overexpressing Sca1 cells we measured both bone formation and resorption markers. We saw evidence of a modest increase in bone resorption but a much greater increase in bone formation (Chen et al., 2015).

We also found that PDGFB stem cell therapy was prolonged, to the extent that the new trabecular bone takes a considerable portion of the marrow cavity. This is not a disadvantage, because by using transcriptional genetic control, it should be possible to utilize this stem cell gene therapy according to the monitored skeletal needs of the patient; viz, bone density and serum bone formation markers.

In the present study and in our previous study we found that the increase in bone formation was attended by an increase in bone strength. Because of the effect of our therapy to increase endosteal and trabecular bone, and because our therapy increases bone formation in both red marrow and fatty marrow sites, it is anticipated that endosteal and trabecular bone formation would be increased throughout the skeleton with this novel therapeutic regimen.

There were 2 unexpected findings in our study. First, in the 2 groups that were OVX, the engraftment of our Sca1⁺ cells was somewhat less than we have seen previously in non-OVX mice (Chen et al., 2015; Hall et al., 2007). In this regard, there are several studies suggesting that estradiol has an impact on hematopoietic stem cells. Accordingly, in mice estradiol increases the retention of hematopoietic stem cells in the vascular niche in the bone marrow (Kim et al., 2017). Also estrogen receptor alpha promotes mouse hematopoietic stem cell regeneration (Chapple et al., 2018). Estrogen also promotes hematopoietic stem cell renewal (Nakada et al., 2014). Probably relevant to the current study, radiation significantly decreased marrow cellularity and increased the amount of marrow adipose tissue in OVX mice compared to intact mice (Hui et al., 2012). In aggregate, these findings suggest that OVX may have modestly impaired engraftment of our Sca 1 cells. Consequently, in the 2 groups of mice with OVX and PDGFB therapy there was a significant decrease in engraftment. This unexpected finding revealed the greater potency for increases in bone density in the PDGFB-DSS6 group over the PDGFB group.

Second, we did not detect a drop in total or cortical bone density in response to OVX control mice. We have no definitive explanation for these negative results. This could be related to the fact that there was a simultaneously decrease in ovarian estrogen production and a bone repletion formation process following radiation preconditioning, which causes bone loss (Hu et al., 2010; Georgiou et al., 2012). In any case, we did see a statistically significant increase in cortical porosity in the Sca1⁺ GFP in the Sca1⁺ PDGFB groups, compared to the non-OVX group. It seems likely that this is an OVX consequence. Noteworthy is that the Sca1⁺ PDGFB-DSS6 group completely eliminated the increased porosity attributable to OVX. Thus our therapy mainly counteracts the effects of OVX also the well-established effects of radiation bone damage (Hu et al., 2010; Georgiou et al., 2012). Once marrow transplantation is conducted with nontoxic preconditioning (see below) the anabolic effects of our stem cell gene therapy may be even more substantial. One interesting potential of our stem cell gene therapy is a possibility that mechanical loading at specific sites of the skeleton would act to determine the distribution of new bone formation, allowing for fortification of bone strength at specific sites considered to be a risk for fracture. Considerable future work needs to be accomplished to optimize our stem cell gene therapy.

An alternative to our marrow transplant for targeting our anabolic stem cell gene therapy to the sites of bone loss would be to utilize PDGFB-DSS6 fusion protein in insulin pump type of administration or by subcutaneous injection. However in both of these approaches there would be a greater chance for extra skeletal effects of PDGFB than what

would occur with our Sca 1⁺ PDGFB-DSS6 therapeutic. With regards to the alternative strategy, our preliminary data with the direct IV injections of PDGFB-DSS6 protein increased the bone formation in in lumbar vertebrae (Fig. 8) in a dose-dependent manner. These results demonstrate that injection of PDGFB-DSS6 protein is efficacious.

In regard to safety in our previous study we saw no changes in peripheral red blood count of white blood count and no changes in soft tissue organs with the exception an enlarged spleen. We attributed the increased spleen size to extra medullary hematopoiesis, because much of the marrow cavity was overtaken by trabecular bone (Chen et al., 2015). Regarding the adverse effects from preconditioning, there are novel approaches in the process of development that could substantially reduce the risk associated with preconditioning. Accordingly, an antibody technology to reduce the endogenous CD45 HSC, c-kit, is now in clinical trials (Czechowicz et al., 2018). This therapy does not require any toxic preconditioning and the only risk is a reduced white blood cell count for approximately 2 weeks. Also, a valine deficient diet, which has a temporary nutritionally toxic effect on hematopoietic stem cells, has shown positive results for preconditioning in both mice and humans (Taya et al., 2016). Therefore, in the future there is a possibility that the adverse effects of preconditioning can be minimized to the extent that the benefit to risk ratio would be sufficiently high to justify HSC-PDGFB therapy for a subpopulation of severely osteoporotic patients. This therapy would be expensive but current anabolic therapies are also expensive (Martin, 2014).

As with any anabolic agent, there is a concern that PDGFB therapy might cause oncogenic effects on extra skeletal bone or organ fibrosis. That PDGFB does not produce heterotrophic bone formation was recently demonstrated in the publication on four subjects with Kosaki disease, which is caused by a gain of function through overexpression of PDGFRB (Minatogawa et al., 2017; Gawlinski et al., 2018). These patients exhibited longitudinal skeletal overgrowth without heterotrophic bone formation or evidence of oncogenesis. A soft tissue untoward effect was myofibromatosis. Nonetheless, for our therapy further oncogenic studies of and fibrotic actions will be required in future studies.

Only limitation of our current study is the lack of tissue distribution analysis of PDGFB-DSS6. Relevant to this issue is that when PDGFB was given systemically to rats, there is an increase in bone formation but this was attended by liver and kidney fibrosis (Mitlak et al., 1996), which was most likely due to an elevated blood level of PDGFB. However, in our previous study where we targeted the PDGFB with the bone marrow transplant, we saw no increase in fibrosis of soft tissue organs and there was no increase in serum PDGFB (Chen et al., 2015). With our current study there would be even less likelihood increased serum PDGFB or increased soft tissue fibrosis because of the targeting action of DSS6. In any case, it will be important in future studies to perform a thorough tissue distribution of PDGFB and of PDGFB-DSS6.

In conclusion, the results of this proof of principle study together with those findings in our previous study (Chen et al., 2015) strongly suggest that our robust anabolic agent coupled with successful skeletal targeting mechanism has the potential to increase bone density and strength at sites in the skeleton where bone is lost during osteoporosis. For this therapy to be applied clinically, new strategies in bone marrow transplant conditioning will need to be substituted for toxic preconditioning (Hui et al., 2012).

Acknowledgements

Funding

This work was supported by the Telemedicine and Advanced Technology Research Center (TATRC) at the US Army Medical Research and Materiel Command (USAMRMC) under grant no. W81XWH-12-1-0023 (DJB). The views, opinions and/or findings contained in this report are those of the author(s) and should not be construed as an official Department of the Army position, policy or decision unless so

designated by other documentation.

Author contributions

WC, SW, YF, LA, and CHR, performed the experiments. CHR, K-HWL, DJB, and XZ interpreted the data. XZ and DJB conceived, directed, and supervised the study. K-HWL provided critical reading of the manuscript, all authors reviewed the manuscript.

Declaration of competing interests

The authors declare that they have no competing interests.

References

- Ascenzi, M.G., et al., 2012. Parathyroid hormone treatment improves the cortical bone microstructure by improving the distribution of type I collagen in postmenopausal women with osteoporosis. *J. Bone Miner. Res.* 27 (3), 702–712.
- Augat, P., Schorlemmer, S., 2006. The role of cortical bone and its microstructure in bone strength. *Age Ageing* 35 (Suppl. 2), ii27–ii31.
- Calvi, L.M., et al., 2001. Activated parathyroid hormone/parathyroid hormone-related protein receptor in osteoblastic cells differentially affects cortical and trabecular bone. *J. Clin. Invest.* 107 (3), 277–286.
- Chanda, D., Kumar, S., Ponnazhagan, S., 2010. Therapeutic potential of adult bone marrow-derived mesenchymal stem cells in diseases of the skeleton. *J. Cell. Biochem.* 111 (2), 249–257.
- Chapple, R.H., et al., 2018. ERalpha promotes murine hematopoietic regeneration through the Ire1alpha-mediated unfolded protein response. *Elife* 7.
- Chen, W., et al., 2015. PDGFB-based stem cell gene therapy increases bone strength in the mouse. *Proc. Natl. Acad. Sci. U. S. A.* 112 (29), E3893–E3900.
- Czechowicz, A., et al., 2018. Selective HSC-ablation using CD117 antibody-drug-conjugates enables safe and effective murine and human hematopoietic stem cell transplantation. *Mol. Ther.* 26 (5), 23–24.
- Fang, R.C., Galiano, R.D., 2008. A review of becaplermin gel in the treatment of diabetic neuropathic foot ulcers. *Biologics* 2 (1), 1–12.
- Farr, J.N., et al., 2016. Identification of senescent cells in the bone microenvironment. *J. Bone Miner. Res.* 31 (11), 1920–1929.
- Gawliński, P., et al., 2018. Phenotype expansion and development in Kosaki overgrowth syndrome. *Clin. Genet.* 93 (4), 919–924.
- Georgiou, K.R., Hui, S.K., Xian, C.J., 2012. Regulatory pathways associated with bone loss and bone marrow adiposity caused by aging, chemotherapy, glucocorticoid therapy and radiotherapy. *Am J Stem Cells* 1 (3), 205–224.
- Graeff, C., et al., 2015. Administration of romosozumab improves vertebral trabecular and cortical bone as assessed with quantitative computed tomography and finite element analysis. *Bone* 81, 364–369.
- Gutteridge, D.H., et al., 2002. A randomized trial of sodium fluoride (60 mg) +/- estrogen in postmenopausal osteoporotic vertebral fractures: increased vertebral fractures and peripheral bone loss with sodium fluoride; concurrent estrogen prevents peripheral loss, but not vertebral fractures. *Osteoporos. Int.* 13 (2), 158–170.
- Hall, S.L., et al., 2007. Sca-1(+) hematopoietic cell-based gene therapy with a modified FGF-2 increased endosteal/trabecular bone formation in mice. *Mol. Ther.* 15 (10), 1881–1889.
- Hu, W.W., et al., 2010. Bone regeneration in defects compromised by radiotherapy. *J. Dent. Res.* 89 (1), 77–81.
- Hui, S.K., et al., 2012. The influence of therapeutic radiation on the patterns of bone marrow in ovary-intact and ovariectomized mice. *PLoS One* 7 (8), e42668.
- Kanis, J.A., 1994. Assessment of fracture risk and its application to screening for postmenopausal osteoporosis: synopsis of a WHO report. WHO Study Group. *Osteoporos. Int.* 4 (6), 368–381.
- Kawai, M., et al., 2011. Emerging therapeutic opportunities for skeletal restoration. *Nat. Rev. Drug Discov.* 10 (2), 141–156.
- Kim, J.Y., et al., 2017. Multicenter phase II clinical trial of Genexol-PM(R) with gemcitabine in advanced biliary tract cancer. *Anticancer Res.* 37 (3), 1467–1473.
- Kleerekoper, M., Balena, R., 1991. Fluorides and osteoporosis. *Annu. Rev. Nutr.* 11, 309–324.
- Kleerekoper, M., et al., 1991. A randomized trial of sodium fluoride as a treatment for postmenopausal osteoporosis. *Osteoporos. Int.* 1 (3), 155–161.
- Martin, T.J., 2014. Bone biology and anabolic therapies for bone: current status and future prospects. *J. Bone Metab.* 21 (1), 8–20.
- McClung, M.R., 2018. Romosozumab for the treatment of osteoporosis. *Osteoporos. Sarcopenia* 4 (1), 11–15.
- McClung, M.R., et al., 2014. Romosozumab in postmenopausal women with low bone mineral density. *N. Engl. J. Med.* 370 (5), 412–420.
- McClung, M.R., et al., 2018. Effects of 24 months of treatment with romosozumab followed by 12 months of Denosumab or placebo in postmenopausal women with low bone mineral density: a randomized, double-blind, phase 2, parallel group study. *J. Bone Miner. Res.* 33 (8), 1397–1406.
- Minatogawa, M., et al., 2017. Expansion of the phenotype of Kosaki overgrowth syndrome. *Am. J. Med. Genet. A* 173 (9), 2422–2427.
- Minisola, S., et al., 2017. New anabolic therapies for osteoporosis. *Intern. Emerg. Med.* 12 (7), 915–921.
- Mitlak, B.H., et al., 1996. The effect of systemically administered PDGF-BB on the rodent skeleton. *J. Bone Miner. Res.* 11 (2), 238–247.
- Nakada, D., et al., 2014. Oestrogen increases haematopoietic stem-cell self-renewal in females and during pregnancy. *Nature* 505 (7484), 555.
- Neer, R.M., et al., 2001. Effect of parathyroid hormone (1-34) on fractures and bone mineral density in postmenopausal women with osteoporosis. *N. Engl. J. Med.* 344 (19), 1434–1441.
- Osteoporosis: Fragility Fracture Risk: Osteoporosis: Assessing the Risk of Fragility Fracture. London.
- Panula, J., et al., 2011. Mortality and cause of death in hip fracture patients aged 65 or older: a population-based study. *BMC Musculoskelet. Disord.* 12, 105.
- Papapoulos, S.E., 2015. Anabolic bone therapies in 2014: new bone-forming treatments for osteoporosis. *Nat. Rev. Endocrinol.* 11 (2), 69–70.
- Rubin, M.R., Bilezikian, J.P., 2002. New anabolic therapies in osteoporosis. *Curr. Opin. Rheumatol.* 14 (4), 433–440.
- Rubin, C.D., et al., 2001. Sustained-release sodium fluoride in the treatment of the elderly with established osteoporosis. *Arch. Intern. Med.* 161 (19), 2325–2333.
- Schnell, S., et al., 2010. The 1-year mortality of patients treated in a hip fracture program for elders. *Geriatr Orthop Surg Rehabil* 1 (1), 6–14.
- Seeman, E., 2013. Age- and menopause-related bone loss compromise cortical and trabecular microstructure. *J. Gerontol. A Biol. Sci. Med. Sci.* 68 (10), 1218–1225.
- Taya, Y., et al., 2016. Depleting dietary valine permits nonmyeloablative mouse hematopoietic stem cell transplantation. *Science* 354 (6316), 1152–1155.
- Thompson, D.D., et al., 1995. FDA guidelines and animal models for osteoporosis. *Bone* 17 (4 Suppl), 125S–133S.
- Yarbrough, D.K., et al., 2010. Specific binding and mineralization of calcified surfaces by small peptides. *Calcif. Tissue Int.* 86 (1), 58–66.
- Zhang, G., et al., 2012. A delivery system targeting bone formation surfaces to facilitate RNAi-based anabolic therapy. *Nat. Med.* 18 (2), 307–314.